

TL15-363826 SAFE WITH INTERIOR  
 36"H X 38"W X 26"D  
 1/2" STEEL BODY & DOOR  
 PAINTED: BLACK  
 RIGHT SWING  
 S&G MECHANICAL COMBO LOCK

BUILT-IN INTERIOR  
 18" DEEP  
 PAINTED: BLACK  
 GOLD HINGES  
 SIX (6) 5" X 16" SST CLADDED ALUM DOORS  
 SINGLE NOSE SDB LOCKS  
 TWO (2) 15" X 16" SST CLADDED ALUM DOORS  
 S&G MECHANICAL COMBO LOCKS  
 TWO (2) ADJUSTABLE SHELVES  
 (ONE PER OPENING)

APPROVED BY: \_\_\_\_\_

DATE: \_\_\_\_\_

VAULT STRUCTURES INC REVISIONS			
REV.	DESCRIPTION	DATE	APPROVED

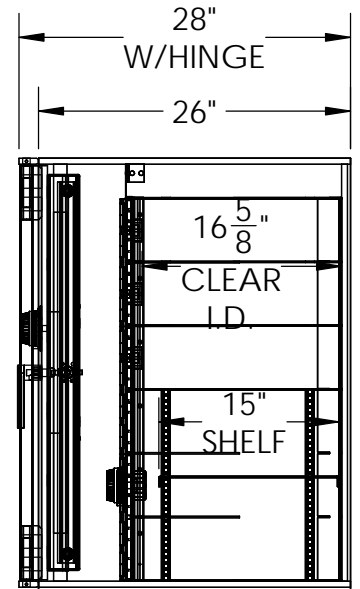
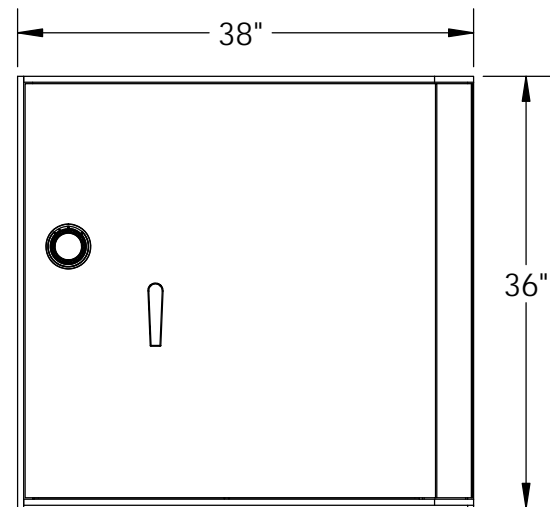
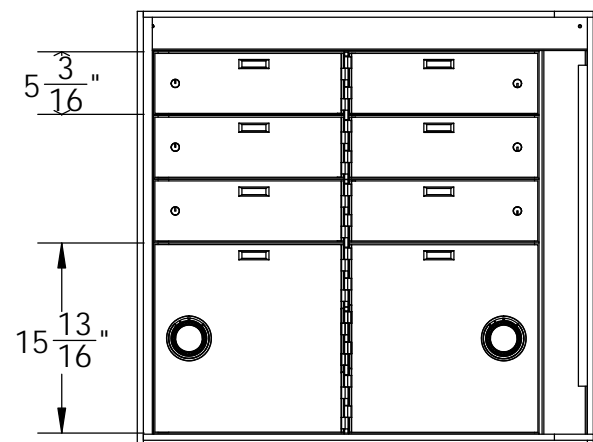
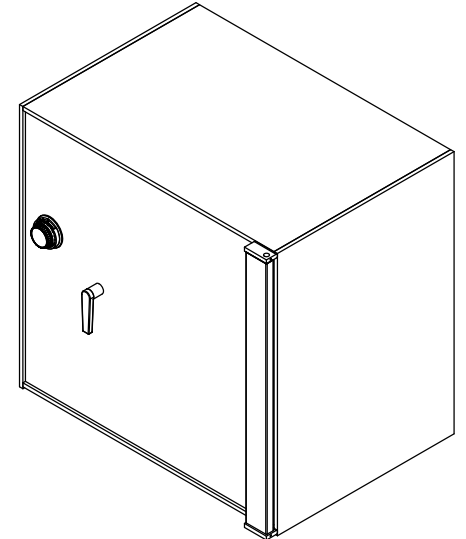
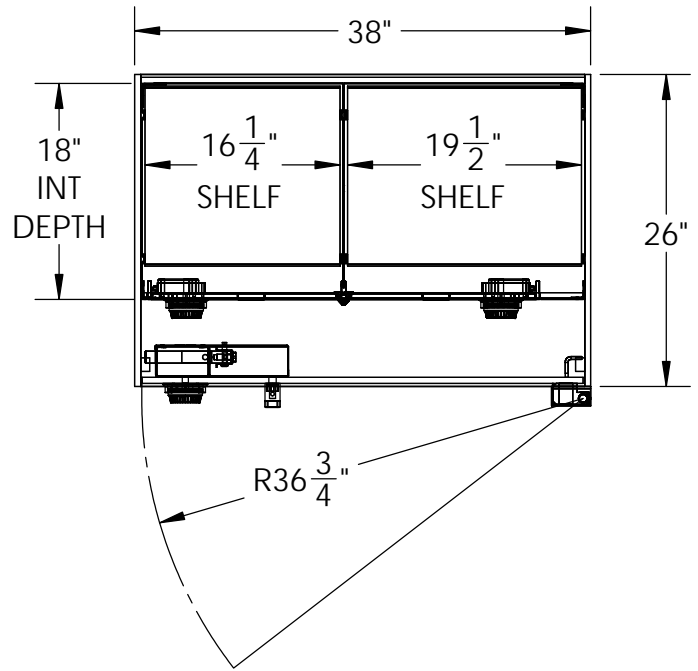

**Vault Structures, Inc.**  
 3640 WORK DRIVE,  
 FORT MYERS, FL 33916  
 Telephone: 239-332-3270  
 Fax: 239-332-5593

**PROPRIETARY AND CONFIDENTIAL**  
 THE INFORMATION CONTAINED IN THIS DRAWING IS THE SOLE PROPERTY OF VAULT STRUCTURES, INC. ANY REPRODUCTION IN PART OR AS A WHOLE WITHOUT THE WRITTEN PERMISSION OF VAULT STRUCTURES, INC IS PROHIBITED.

MATERIAL :  
 GAUGE :  
 GRAIN :  
 BEND RAD. :  
 K-FACTOR:

DWG. NO. TL15-363826 HALF IN RS  
 TITLE: TBD

DRAWN BY: MA  
 MODEL BY:

WEIGHT: 1172.41  
 SCALE: 1:16

DATE: 3/25/2015  
 SHEET 1 OF 1

REV  
 X