

TL15-363826 SAFE WITH INTERIOR
 36"H X 38"W X 26"D
 1/2" STEEL BODY & DOOR
 PAINTED: BLACK
 LEFT SWING
 S&G MECHANICAL COMBO LOCK

BUILT-IN INTERIOR
 18" DEEP
 PAINTED: BLACK
 GOLD HINGES
 SIX (6) 5" X 16" STEEL PAINTED DOORS
 SINGLE NOSE SDB LOCKS
 TWO (2) 15" X 16" STEEL PAINTED DOORS
 S&G MECHANICAL COMBO LOCKS
 TWO (2) ADJUSTABLE SHELVES
 (ONE PER OPENING)

APPROVED BY: _____

DATE: _____

VAULT STRUCTURES INC REVISIONS			
REV.	DESCRIPTION	DATE	APPROVED

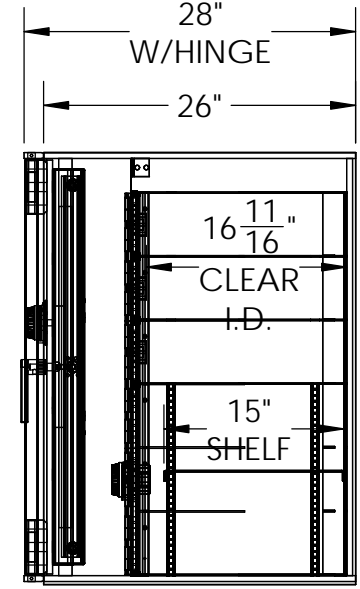
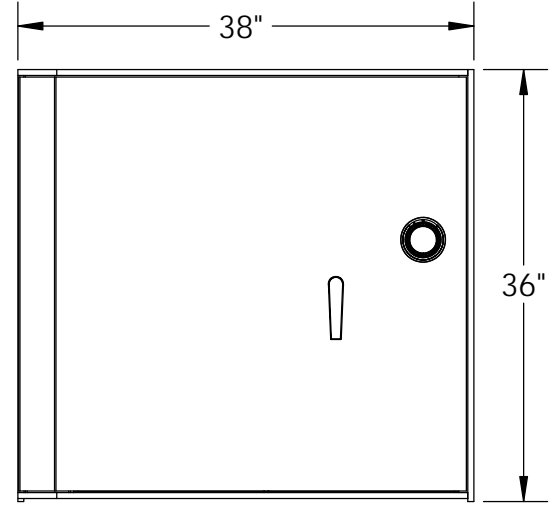
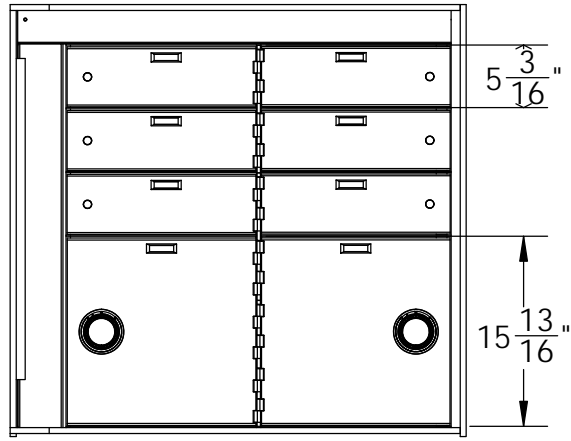
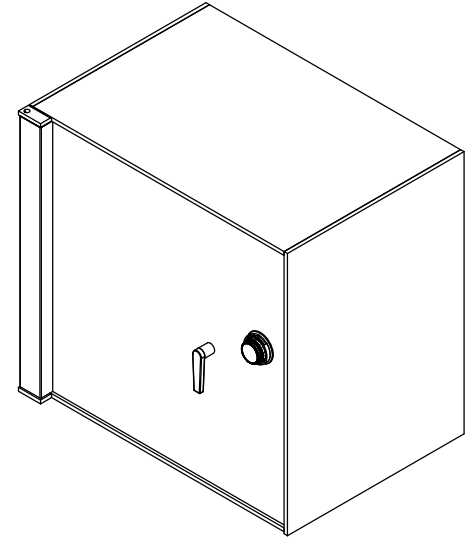
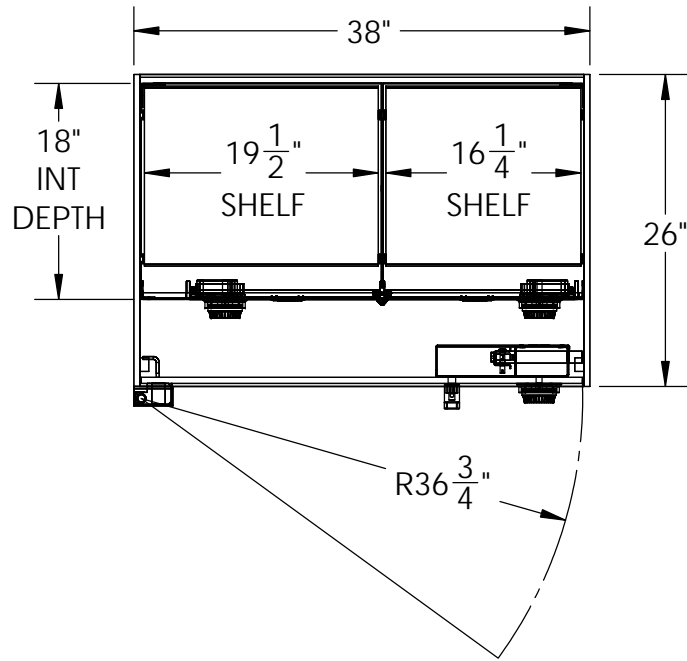

Vault Structures, Inc.
 3640 WORK DRIVE,
 FORT MYERS, FL 33916
 Telephone: 239-332-3270
 Fax: 239-332-5593

PROPRIETARY AND CONFIDENTIAL
 THE INFORMATION CONTAINED IN THIS DRAWING IS THE SOLE PROPERTY OF VAULT STRUCTURES, INC. ANY REPRODUCTION IN PART OR AS A WHOLE WITHOUT THE WRITTEN PERMISSION OF VAULT STRUCTURES, INC IS PROHIBITED.

MATERIAL :
 GAUGE :
 GRAIN :
 BEND RAD. :
 K-FACTOR:

DWG. NO. TL15-363826 HALF IN LS
 TITLE: TBD

DRAWN BY: MA
 MODEL BY:

WEIGHT: 1159.41
 SCALE: 1:16

DATE: 3/25/2015
 SHEET 1 OF 1

REV
 X