

STANDARD

NML-3-33 LOCKER

32.625W X 32.25H X 24.00D

CASE PAINTED BLACK

PAINTED STEEL DOORS

GOLD HINGES (OPTIONAL: BLACK)

S&G COMBO LOCKS

ONE (1) ADJUSTABLE SHELF

AVAILABLE OPTIONS:

BRUSHED ALUMINUM DOORS
SST CLAD ALUM DOORS

APPROVED BY: _____

DATE: _____

NUMBERING: _____

VAULT STRUCTURES INC REVISIONS

REV.	DESCRIPTION	DATE	APPROVED
------	-------------	------	----------

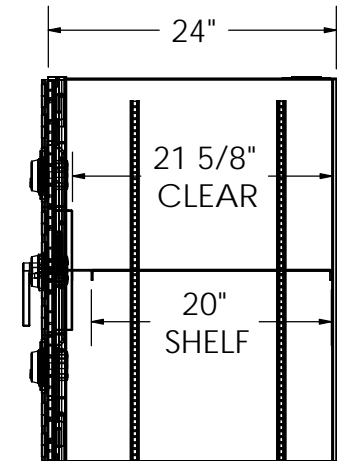
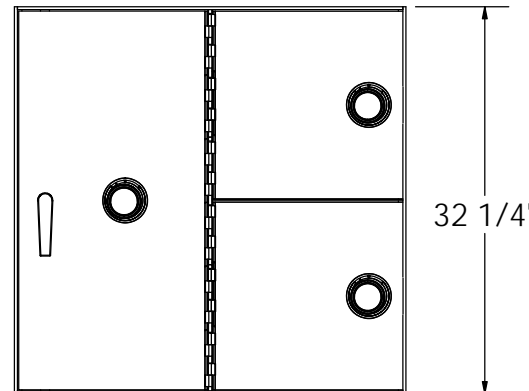
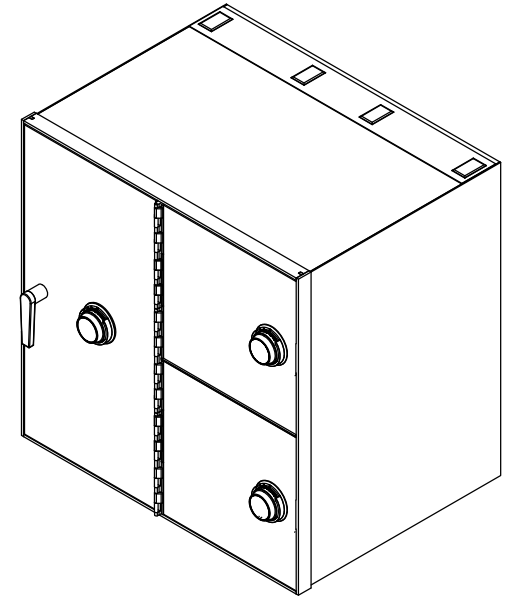
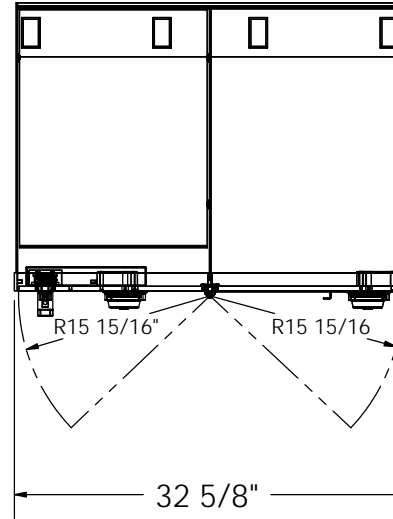

Vault Structures, Inc.
3640 WORK DRIVE,
FORT MYERS, FL 33916,
Telephone: 239-332-3270
Fax: 239-332-5593

PROPRIETARY AND CONFIDENTIAL
THE INFORMATION CONTAINED IN
THIS DRAWING IS THE SOLE
PROPERTY OF VAULT STRUCTURES,
INC. ANY REPRODUCTION IN PART
OR AS A WHOLE WITHOUT THE
WRITTEN PERMISSION OF VAULT
STRUCTURES, INC IS PROHIBITED.

MATERIAL :
GAUGE :
GRAIN :
BEND RAD. :
K-FACTOR:

DWG. NO. NML-3-33 PROD
TITLE:

DRAWN BY: SAC
MODEL BY:

WEIGHT: 116.51
SCALE: 1:16

DATE: 10/21/2013
SHEET 1 OF 5

REV
A