

STANDARD

NML-1-22 LOCKER
 21 5/8"H X 16 3/4"W X 24"D
 CASE PAINTED BLACK
 PAINTED STEEL DOORS
 GOLD HINGES (OPTIONAL: BLACK)
 S & G COMBO LOCK
 ONE (1) ADJUSTABLE SHELF

AVAILABLE OPTIONS:
 BRUSHED ALUMINUM DOORS
 SST CLAD ALUM DOORS

APPROVED BY: _____

DATE: _____

NUMBERING: _____

VAULT STRUCTURES INC REVISIONS			
REV.	DESCRIPTION	DATE	APPROVED

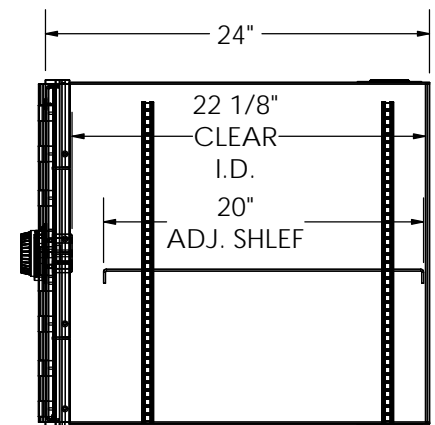
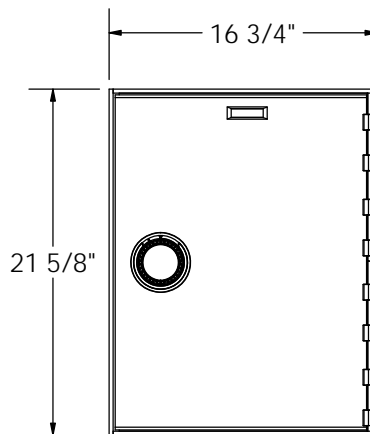
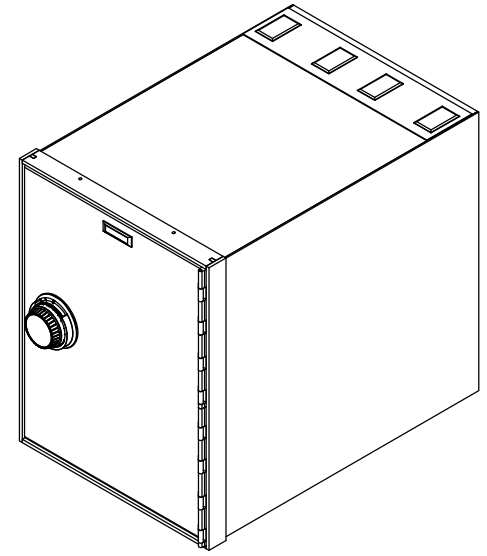
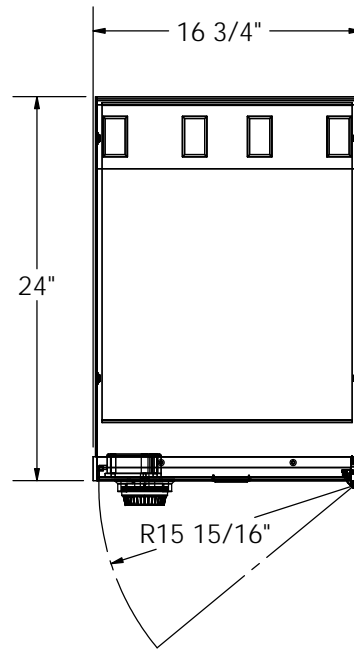

Vault Structures, Inc.
 3640 WORK DRIVE,
 FORT MYERS, FL 33916,
 Telephone: 239-332-3270
 Fax: 239-332-5593

PROPRIETARY AND CONFIDENTIAL
 THE INFORMATION CONTAINED IN
 THIS DRAWING IS THE SOLE
 PROPERTY OF VAULT STRUCTURES,
 INC. ANY REPRODUCTION IN PART
 OR AS A WHOLE WITHOUT THE
 WRITTEN PERMISSION OF VAULT
 STRUCTURES, INC IS PROHIBITED.

MATERIAL :
 GAUGE :
 GRAIN :
 BEND RAD. :
 K-FACTOR:

DWG. NO. NML-1-22
 TITLE: TBD

DRAWN BY: XXX
 MODEL BY:

WEIGHT: 99.12
 SCALE: 1:12

DATE: 6/17/2014
 SHEET 1 OF 1

REV
X